

# The Business Page



March 2004

**Important Phone Numbers:**

**General Township Government**  
**453-3840**

**Steve Mann, Supervisor**  
**354-3201**

**Marilyn Massengill, Clerk**  
**354-3224**

**Ron Edwards, Treasurer**  
**354-3214**

**Trustees:**  
**Kay Arnold**  
**455-2683**

**Charles Curmi**  
**455-9658**

**Ron Griffith**  
**455-1083**

**Abe Munfakh**  
**459-7547**

**Police, Fire, EMS Emergencies 911**  
**Police non-emergency**  
**453-3869**

**Building Dept.**  
**354-3208**

**Public Services**  
**453-8131**

## Township named “Hot Town” by *Money*

Plymouth Township was recognized by *Money* magazine as one of the country’s “Hottest Towns”, calling it one of the most desirable places to live in America.

In the magazine’s January issue, the article says that researchers used several criteria to come up with the list. The study took into account median household income, median home price, availability of recreational and cultural opportunities, and proximity to a major city. Just one other community in Michigan (West Bloomfield) made the list.

Township officials were pleased, but not surprised, to learn of the recognition. “We’ve known all along that this is a great community with lots to offer” commented

Supervisor Steve Mann. “Now people across the country will be aware of it, too. We have the lowest tax rate in Wayne County and are able to offer excellent services to our residents. The Plymouth-Canton School District is exceptional; the Plymouth Symphony, Plymouth Community Arts Council and the Plymouth Historical Museum offer varied cultural opportunities; and our recreational offerings continue to grow with the addition of the Sprayscape to our park in 2003 and the anticipated opening of the Lake Pointe Soccer Park later this year.”

The article can be viewed at:  
[http://money.cnn.com/best/bplive/cities\\_table/](http://money.cnn.com/best/bplive/cities_table/).

## DDA update: streetscape coming in fall

The Ann Arbor Road corridor facelift will continue this year thanks to a financial boost from a grant awarded by the State of Michigan in the amount just over \$700,000. The Township will provide matching funds of \$430,000. This funding will allow the Township to kick-off the revitalization of the corridor earlier than anticipated. This area begins at the eastern Township boundary line at Eckles Road and continues west to Haggerty Road.

The Township applied for funding to improve this specific area because it is the Township’s main commercial corridor and main entrance to the community. The State of Michigan will benefit as well from the enhancements to the I-275/Ann Arbor Road interchange.

Improvements will concentrate on the area from curbside up to the sidewalk and

include a two-foot wide concrete verge to create an aesthetic transition from the roadway to the grassy area. Other features will be the addition of street trees, decorative lighting and flowers.

The area beyond the sidewalk, generally between the sidewalk and parking lot, will benefit from the Township’s matching funds which will provide for decorative fencing with brick columns, and lush landscaping with an irrigation system. The Township is currently pursuing easements from property owners to make these improvements possible. So far, there has been great cooperation from owners who recognize it as a great opportunity to improve the frontage of their businesses without any cost.

*please see “Streetscape” on page two*

## New Police/Fire/Township Hall Update: Committee reviews bids for architectural services

The Township is prepared to move forward now in the pursuit of a new facility to house Police, Fire and Township services. On November 6, 2003, Township voters approved a bond proposal allowing the Township to issue \$6M in municipal bonds. The bond proceeds, combined with an additional \$6M from current assets, will allow the Township to build the new complex without any tax increase. Township officials are enthusiastic about the progress being made on this long overdue project.

Supervisor Steve Mann has formed an Advisory Committee to get the next stage of the plan going. The Township Hall Building Committee, chaired by Chief Building Official Mark Lewis, includes a cross section of active community residents and elected officials who will make recommendations to the Board of Trustees for consideration. The Committee also includes residents Harry Jachym, Steve O'Connor, and Bob Zaetta, along with Township Clerk Marilyn Massengill, and Treasurer Ron Edwards.

The Committee met during January and February to discuss details of the Request For Proposals (RFP) for architectural services. The Committee set a deadline of March 5, 2004, 3:00 pm for proposals to be submitted to the Clerk's Office. They will now review the proposals and submit their recommendation for consideration by the Board of Trustees.

The new home for the Township offices will be located on Haggerty near Ann Arbor Road on a 9.5-acre parcel. The Township closed on the purchase of the property in early March. Once the complex has been designed, the Township expects to bid the project out for construction in the fall. Groundbreaking is expected during late 2004 or spring 2005. Construction of the new facilities is expected to take 10-12 months.

More information is available on the Plymouth Township website [www.plymouthtwp.org](http://www.plymouthtwp.org). Click on the scrolling applet on the home page for a list of FAQ's about the new Township Hall.

## State to close Western Wayne Correctional Facility

Plymouth Township officials were pleased to learn that the State of Michigan plans to close the Western Wayne Correctional Facility on Five Mile Road in the Township. Governor Jennifer Granholm made the announcement as part of her 2004-05 budget plan. The closure is expected to save the state \$22.7 million.

Western Wayne currently houses over 800 female prisoners who will likely be transferred to the Huron Valley facility in Ypsilanti by October. Reasons cited for the closure include current economic conditions in the State, as well as environmental concerns.

This welcome news is a complete turn of events from just last year when discussions included the possibility of a 400 bed expansion at the site. The Township looks forward to redevelopment of the 127-acre prison site.

The site borders the Township's extensive Research and Development corridor and will be a welcome addition to the tax roll. The location is adjacent to a 100-acre parcel recently sold by the City of Detroit to the DeMattia Group. Johnson Controls is pursuing plans to expand their Automotive Group Headquarters on that property.

## Streetscape (continued from page one)

All of this activity follows months of planning by the Downtown Development Authority (DDA) which was put in place to revitalize the corridor. The DDA captures a portion of tax revenue from within the district which is then earmarked for reinvestment for improvements to the corridor. In the coming years, as more money becomes available, the DDA will continue streetscape construction from Haggerty Road west to a point just west of Sheldon.

The nine-member DDA is chaired by Supervisor Steve Mann. The majority of members have a business interest in the Ann Arbor Road corridor. Members include Mike Kolb of Hines Park Lincoln, Dave Cook of the Trading Post, Jim Grutza of Papa Romano's, and Tom Bohlander representing New Liberty Bank. The remaining members are Township residents Arlene Karell, Elaine Hovey, Si Nahra, and Michelle Ludtke.

# New for 2004—ice skating and soccer!

There's even more winter fun to be had at Plymouth Township Park this year! A new ice skating rink has been created, right next to the Sprayscape, near the entrance to the park. The rink was open for a trial period for several weeks this winter and will be ready for skaters when cold weather returns again at the end of the year.

The other main cold-weather attraction to Plymouth Township Park is the sled hill which has been getting lots of use this winter. The park is located on Ann Arbor Trail at McClumpha (between Beck and Sheldon Roads). Spring-like temperatures this month may signify the closure of the sled hill for this season! Call the park hotline at 453-3567.

Speaking of spring, as soon as weather permits, the Lake Pointe Soccer Park will open. Township officials plan to have a ribbon-cutting ceremony on a date yet to be announced, most likely in June. The soccer park is located on Haggerty Road, just north of Schoolcraft

and the M-14 Expressway. League play will probably begin in late summer.

Some of the many features of the park include one large and one smaller soccer fields, surrounded by a walking path. There are restrooms and a shelter, which is



Lake Pointe Soccer Park offers two soccer fields for league play, a picnic and children's play areas, restrooms, and a shelter available for rental.

available for rental. A picnic and children's play area are also on site to make it a family-friendly place. For further information on the park, shelter reservations and use of the soccer fields, contact Susan Vignoe at 453-8131, ext. 33.

## Watershed wisdom: oil/water separator maintenance

Oil/Water separators are designed to remove sediment, oil, and grease from storm water runoff. Chances are if you have a site with heavy traffic or high potential for petroleum spills, you have an oil/water separator. An example of a simple separator is shown below.

Oil/Water separators cannot function properly unless they are regularly maintained. To ensure that separators are properly maintained, it is a good idea to hire a professional service. Make sure that wastes are taken to a licensed treatment facility, where the oil will be further separated for recycling.

Why worry? If oil is allowed to enter the Rouge River, only four quarts, the amount it takes to fill an automobile's engine, can form an eight-acre oil slick in a river.

One quart of oil can contaminate up to two million gallons of water.

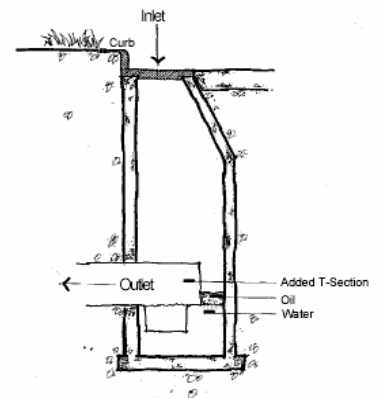
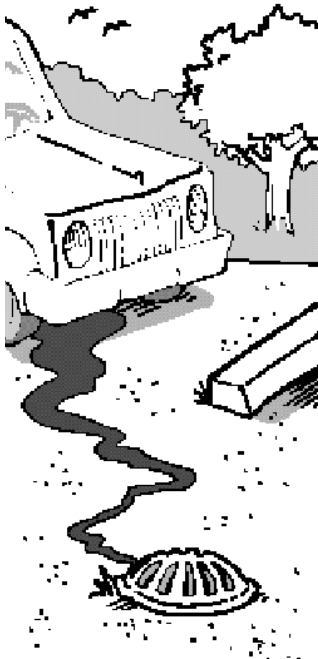

Simple Oil/Water Separator

# Some truth about false alarms



Fact: 93% of all false alarms are caused by human error. According to Community Resource Officer Jamie Senkbeil of the Plymouth Township Police Department, a false alarm is defined in Plymouth Township as “any alarm condition which is received at the Police Department, Fire Department or elsewhere, not resulting from the activity for which the alarm was intended.”

You can help stop false alarms. The most common causes of false alarms are:

- System users
- Physical changes to facility
- Displays and decorations
- Malfunctioning equipment
- Heat vents
- Air conditioning vents
- Fan (ceiling and table)
- Small animals



Storms and bad weather should not activate your alarm. Here are some helpful tips to eliminate false alarms:

- Make sure all users have proper knowledge of codes and operations of the alarm. Know how to disarm the alarm.
- If the system was installed for a certain type of facility and remodeling occurs, the alarm should be inspected for suitability to the changes that have been made.
- Carefully arrange all decorations, banners and displays. Floating balloons can interfere with the motion detectors and activate alarms.
- Replace main battery to meet manufacturers specifications.
- Faulty Equipment—if you cannot identify the cause of the activation—contact your alarm

company to have motion detectors checked along with basic equipment.

- Heat rises and can cause enough motion to activate alarms, as can air conditioning currents.
- Motion detectors easily detect small animals (birds, cats, rodents, etc.). Use caution against their entering the premises.
- Schedule routine system maintenance and checks by the alarm company.
- Alarmed areas must be protected from access. Security systems must not be the only barrier—all alarmed doors should have secure locks.

Commercial burglar alarm systems provide protection from intrusion in the event that physical security fails. Here are some steps you can take to prevent false burglar alarms:

1. Before leaving, check that all exterior doors are closed and locked.
2. Before leaving, check that all motion sensor areas are clear of moving signs, displays, reflective/helium balloons, etc.
3. Know how to cancel a false alarm quickly.
4. All personnel should be periodically trained in proper alarm operating procedures and false alarm prevention.
5. Report any arming or disarming problems to your alarm company immediately.

In the event of a false alarm, Officer Senkbeil suggests the following procedure:

1. Turn off the alarm
2. Call the alarm company and provide the pass code
3. Contact the Plymouth Community Communications Center and report the false alarm at 354-3250

Officer Senkbeil can be reached at 354-3243.

**Plymouth Township is on the web at  
[www.plymouthtwp.org](http://www.plymouthtwp.org)**